

IP Router N146

5WG1 146-1AB01

Product and Applications Description



The IP Router N146 is a DIN rail mounted device.

The device connects EIB lines via data networks using the Internet Protocol (IP). Also this device offers communication of EIB devices with PC's or other data processing equipment.

The physical connection to the EIB is established via a bus connector terminal block. For connection to the data network (IP via 10BaseT) the device contains an RJ45 socket.

To operate the IP Router requires AC/DC 24 V, which is provided via a second terminal block. The IP Router is powered via this operating voltage terminal connector. This allows the IP Router to send a bus voltage failure notification onto the data network.

The IP Router implements the EIBnet/IP standard for routing of EIB telegrams between lines and for concurrent access to the bus line from any PC.

By using a LAN modem an EIB installation can be remotely accessed even if there is no direct data network connection between a PC and an IP Router. LAN modems are available on the market for standard telephone, ISDN or DSL connections.

The IP Router has these characteristics:

- Simple connection to hierarchically superimposed systems via Internet Protocol (IP)
- Direct access to the EIB installation from any access point to the IP network (EIBnet/IP Tunneling)
- Fast communication between EIB lines, EIB areas and systems (EIBnet/IP Routing)

- Communication between buildings and facilities
- Filtering and routing of telegrams depending on
 - individual address
 - group address
- LED display of
 - operation
 - EIB communication
 - IP communication
- Simple configuration with standard ETS
- Easy connection to SCADA and Facility Management systems (see: Supported Software)

Using the existing data network for communication between bus lines in non-residential buildings is a logical step. The advantages are: fast communication between EIB lines, extension of an EIB system beyond one building by using LAN and WAN connections, direct transmission of EIB data to any network user, EIB remote configuration from any network access point.

The IP Router N146 logically connects EIB bus lines by transmitting EIB telegrams between them via a data network but separates them galvanically. This allows to run each bus line independently from other bus lines.

The N146 can be used as line coupler or area coupler in existing *EIB* networks as well as in new *KNX EIB* networks. The N146 holds a filter table determining, which bus telegrams are transmitted or blocked from or to the bus line thus reducing the bus load. The filter table is automatically generated by the ETS (*EIB Tool Software*) during configuration and start-up of the system.

The physical address of the IP Router assigned by ETS automatically determines the IP Router function as a line coupler or area coupler. The definition follows these assignments:

Coupler function	Line
Area coupler	Main line 1- 15
Line coupler	Line 1- 15

IP Router N146 **5WG1 146-1AB01**

Note

When assigning the physical address take care that IP Router and line couplers receive the topologically correct physical address (Fig. 1, IP Router as area coupler and line coupler).

Adhere to these rules:

Rule 1:

In general an IP Router N 146 is used as a line coupler or an area coupler. The physical address has the format x.y.0, with x=1...15, y=1...15.

Rule 2:

If an IP Router N 146 is applied as an area coupler with the physical address x.0.0 then no other IP Router with the line coupler address x.y.0 (y=1...15) shall be placed topologically „below“ this IP Router (Fig. 2, IP Router N 146 as area coupler).

Rule 3:

If an IP Router N146 is applied as a line coupler (e.g. with physical address 1.2.0) then no other IP Router N146 shall be used with a superior area coupler address (e.g. 1.0.0) in this installation (Fig. 3, IP Router N 146 as line coupler).

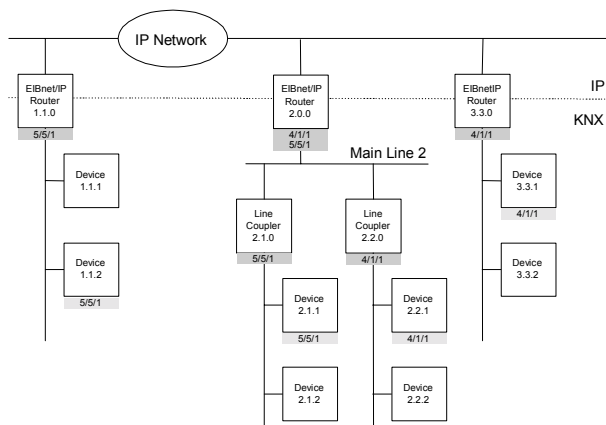

Figure 1. IP Router N 146 as area and line coupler

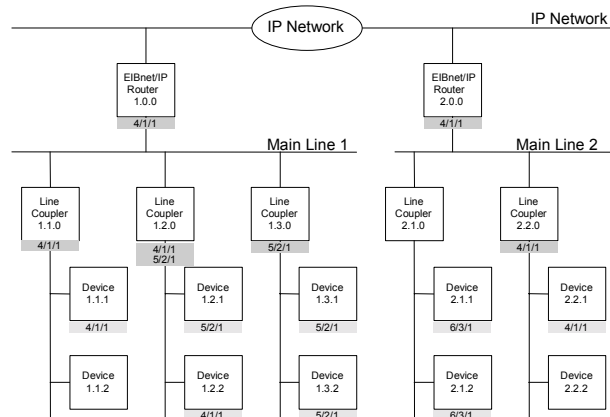

Figure 2. IP Router N 146 as area coupler

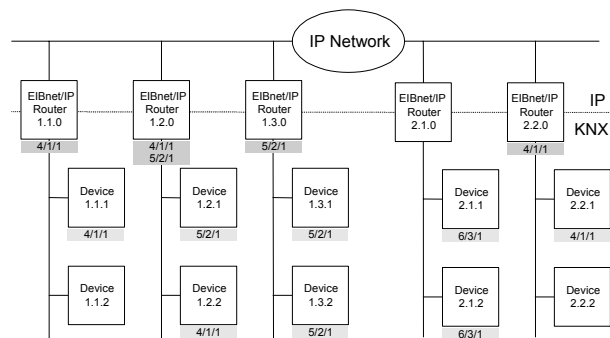

Figure 3. IP Router N 146 as line coupler

IP Router as interface to the bus (EIBnet/IP Tunneling)

A direct connection between a networked PC and the bus can be established via a data network and the IP Router N 146. This allows for accessing the bus from any access point in the data network.

IP address assignment

The IP address of the IP Router N146 is assigned manually using ETS or automatically by a DHCP server in the IP network. Assignment of the IP address by a DHCP server allows for changes of the device IP address without using ETS. Configuration of the DHCP server may require the MAC address, which is printed on the device.

Please consult your network administrator regarding configuration of the parameters device IP address, subnet mask, and DHCP.

IP Router N146**5WG1 146-1AB01**Default factory settings

By default the EIBnet/IP Routing function is active. When two EIBnet/IP routers are connected with each other via a cross-over cable or via a network hub, bus telegrams are routed by the EIBnet/IP Router without any configuration.

The IP Router ships with these default factory settings:

- Physical address of the IP Router: 15.15.0 (= FF00 hex)
- Filter group telegrams
- All bus telegrams are repeated in case of transmission errors
- The IP Router acknowledges routed telegrams only
- Support for devices with mis-matching physical address
- Route broadcast telegrams
- Monitor the bus line

Behavior on bus voltage loss / recovery on the bus line

When the IP Router detects a loss of bus voltage on the bus line, this error is saved and annunciated via EIBnet/IP. When the IP Router detects recovery of bus voltage on the bus line, the error flag is deleted and the resumption of bus voltage is annunciated via EIBnet/IP.

Application programs

The IP Router N146 can be configured with ETS2 v12 or higher.

It requires the application program "**IP Router 001001**".

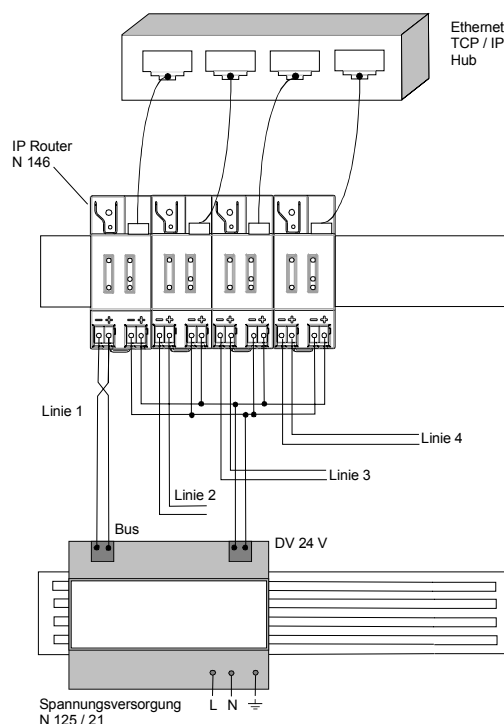
Example of Operation**Installation Instructions**

- The device may be used for permanent interior installations in dry locations within distribution boards or small casings with DIN rail EN 60715-TH35-7,5.

**WARNING**

- The device must be mounted and commissioned by an authorised electrician.
- Free DIN rail areas with sticked-in data rails must be covered with covers, order no. 5WG1 192-8AA01.
- The prevailing safety rules must be heeded.
- The device must not be opened.
- For planning and construction of electric installations, the relevant guidelines, regulations and standards of the respective country are to be considered.

Technical Specifications

Network communication

- Ethernet:
10BaseT (10 Mbit/s)
- Supported Internet Protocols:
ARP, ICMP, IGMP, UDP/IP, DHCP
- EIBnet/IP according to Konnex System Specification:
Core, Routing, Tunneling, Device Management

Rated voltage

- Bus: DC 24V (DC 21...30V)
- Auxiliary power supply:
AC/DC 24V (AC/DC 12...30V)

Power supply

- Bus voltage: via EIB bus line
- Operating voltage:
from external SELV power supply AC/DC 24V nominal,
permissible input voltage range:
AC/DC 12 ... 30 V
- Recommended power supplies:
 - DC 24V (before choke) from EIB power supplies N121, N122, N125/21
 - door bell transformer 4AC2 102, AC 230V / AC 12V (primary / secondary), 1,33A, 2SU width
 - door bell transformer 4AC2 105, AC 230V / AC 12V (primary / secondary), 1,33A, 2SU width

Power usage

- From the bus line: max. 10mA @ DC 29V
- From the auxiliary power supply: max. 800mW (25mA @ DC 24V)

Control elements

1 learning button:
for switching between normal operating mode and addressing mode

Display elements

- 1 green LED: device ready (ON)
- 1 yellow LED: Communication on bus line
- 1 green LED: Ethernet Link Signal available (Lk)
- 1 yellow LED: Receiving data from Ethernet (Rx)
- 1 red LED: Transmitting data to Ethernet (Tx)
- 1 red LED: for monitoring bus voltage and displaying mode, selected with the learning button

Connections

- bus line:
screwless bus connection block (red-black)
0,6...0,8 mm Ø single core
remove approx. 5mm of isolation
- Ethernet / IP network: RJ45 socket
- auxiliary power:
screwless extra low voltage terminal (yellow-white)
Ø 0,6 ... 0,8 mm Ø single core
remove approx. 5mm of isolation

Physical specifications

- housing: plastic
- N-system DIN-rail mounted device,
width: 2 SUs (1SU = 18mm)
- installation: rapid mounting on EN 60715-TH35-7,5 rail
- weight: approx. 100g

Electrical safety

- degree of pollution (according to IEC 60664-1): 2
- protection (according to EN 60529): IP 20
- protection class (according to IEC 61140): III
- overvoltage class (according to IEC 60664-1): III
- bus: safety extra low voltage SELV DC 24 V
- the device complies with EN 50 090-2-2

Electromagnetic compatibility

complies with
EN 61000-6-2 and EN 61000-6-3 and EN 50090-2-2

Environmental specifications

- climatic conditions: EN 50090-2-2
- ambient temperature operating: - 5 ... + 45 °C
- storage temperature: - 25 ... + 70 °C
- relative humidity (non-condensing): 5 % to 93 %

Markings

EIB, KNX, CE

CE mark

complies with the EMC regulations (residential and functional buildings), and low voltage regulations

IP Router N146

5WG1 146-1AB01

Location and Function of the Display and Operator Elements

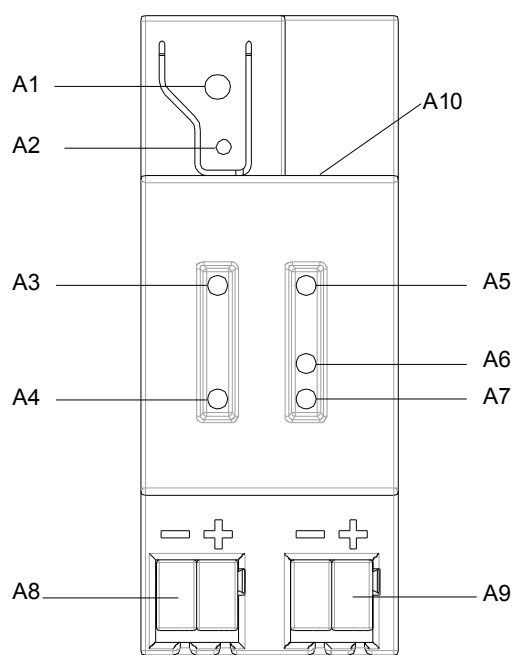

Figure 4: Location of the display and operator elements

- A1 LED red: indicating normal operating mode (LED off) and addressing mode (LED on)
- A2 learning button for switching between normal operating mode and addressing mode for receiving the physical address
- A3 LED green: Operation
- A4 LED yellow: data transmission on bus line (Line)
- A5 LED green: Ethernet Link signal (Lk)
- A6 LED yellow: Ethernet Receive signal (Rx)
- A7 LED red: Ethernet Transmit signal (Tx)
- A8 extra low-voltage bus terminals (red-black)
- A9 extra low-voltage terminals (yellow-white)
- A10 RJ45 socket for data network cable

Mounting and Wiring

General description

The N-system DIN-rail device can be installed in N-system distribution boards, surface or flush mounted, or on any DIN rail complying with EN 60715-TH35-7,5. The connection to the bus line is established via the bus connector terminal (red-black) on the top side. The RJ45 socket on the device front side provides the connection to the Ethernet-IP data network.

Mounting DIN-rail devices (Figure 5)

- Slide the device (B1) onto the DIN-rail (B2) and
- swivel back the device until the slide clicks into place audibly.

Dismounting DIN-rail devices (Figure 5)

- Remove all connected wires,
- press down the slide (C3) with a screw-driver and
- swivel the device (C1) from the DIN-rail (C2).

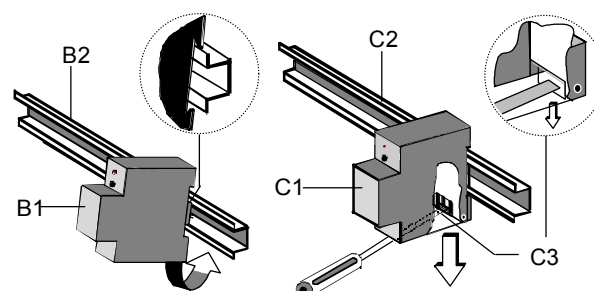

Figure 5: Mounting and dismounting a DIN-rail device

Slipping off bus connection blocks (Figure 6)

- The bus connection block (D2) is situated on the top of the device (D1).
- The bus connection block (D2) consists of two components (D2.1 and D2.2) with four terminal contacts each. Take care not to damage the two test sockets (D2.3) by accidentally connecting them to the bus cable or with the screw-driver (e.g. when attempting to unplug the bus connection block).
- Carefully put the screw-driver to the wire-inserting slit of the bus connection block's grey component and pull the bus connection block (D2) from the device (D1).

Slipping on bus connection blocks (Figure 6)

- Slip the bus connection block onto the guide slot and
- press the bus connection block (D2) down to the stop.

Connecting bus cables (Figure 6)

- The bus connection block (D2) can be used with single core conductors $\varnothing 0,6 \dots 0,8$ mm.
- Remove approx. 5 mm of insulation from the conductor (D2.4) and plug it into the bus connection block (D2) (red = +, black = -).

Disconnecting bus cables (Figure 6)

- Unplug the bus connection block (E1) and remove the bus cable conductor (E1.4) while simultaneously wiggling it.

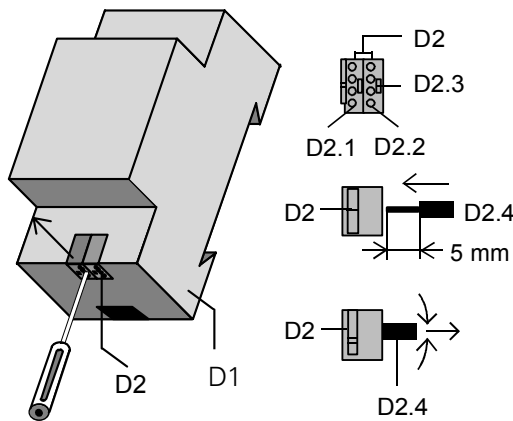

Figure 6: Connecting and disconnecting bus wires

Slipping off / on auxiliary power connection block

- Follow the instructions for the bus connection block when slipping off/on the auxiliary power connection block.

Dimension Diagram

Dimensions in mm

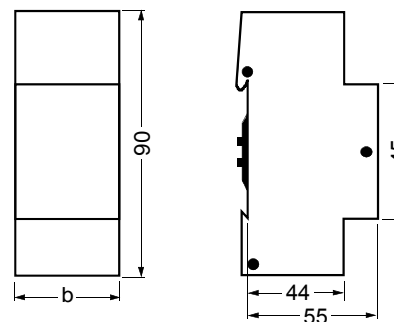

b = 2 SU

1 Standard unit (SU) = 18 mm

Supported Software

Here is a list of software supporting the IP Router N 146.

ComBridge Studio

IPAS GmbH
 Grabenstr 149 a
 47057 Duisburg
 [<http://www.ipas-products.com>]

General Notes

- Any faulty devices should be returned to the local Siemens office.
- If you have further questions about the product, please contact our Technical Support:

☎ +49 (0) 180 50 50-222

☎ +49 (0) 180 50 50-223

✉ adsupport@siemens.com